

## ARTICLE

# PARKIN Inactivation Links Parkinson's Disease to Melanoma

Hui-Han Hu, Caroline Kannengiesser, Suzanne Lesage, Jocelyne André, Samia Mourah, Laurence Michel, Vincent Descamps, Nicole Basset-Seguin, Martine Bagot, Armand Bensussan, Céleste Lebbé, Lydia Deschamps, Philippe Saiag, Marie-Thérèse Leccia, Brigitte Bressac-de-Paillerets, Amel Tsalamlal, Rajiv Kumar, Stephan Klebe, Bernard Grandchamp, Nathalie Andrieu-Abadie, Luc Thomas, Alexis Brice, Nicolas Dumaz\*, Nadem Soufir\*

**Affiliations of authors:** INSERM, U976, Centre de Recherche sur la Peau, Hôpital Saint Louis, Paris, France (HHH, JA, SM, LM, VD, NBS, MB, AB, CL, ND, NS); AP-HP, Hôpital Bichat Claude Bernard, Département de Génétique, Paris, France (HHH, CK, AT, BG, NS); Université Paris Diderot, Sorbonne Paris Cité, UMRS976, Paris, France (HHH, CK, JA, LM, NBS, MB, AB, LD, AT, BG, ND, NS); Université Paris 6, INSERM UMRS975, Centre de Recherche de l'Institut du Cerveau et de la Moelle Epinière, Hôpital Pitié-Salpêtrière, AP-HP, Paris, France (SL, AB); INSERM, U940, Laboratoire de Pharmacologie, Hôpital Saint Louis Paris, France (SM); AP-HP, Hôpital Bichat Claude Bernard, Service de Dermatologie, Paris, France (VD); AP-HP, Hôpital Saint Louis, Service de Dermatologie, Paris, France (NBS, MB, CL, ND); INSERM, CRB3, Département de Pathologie, Hôpital Bichat, AP-HP, Paris, France (LD); AP-HP, Hôpital Ambroise Paré, Service de Dermatologie, Boulogne Billancourt, France (PS); CHU Grenoble, Service de Dermatologie, Grenoble, France (MTL); Gustave Roussy, Service de Génétique, Département de Biopathologie, Villejuif, France (BBdP); Division of Molecular Genetic Epidemiology, German Cancer Research Center, Im Neuenheimer Feld 580, Heidelberg, Germany (RK); Department of Neurology, University Hospital of Würzburg, Würzburg, Germany (SK); Inserm UMR1037, Centre de Recherche en Cancérologie de Toulouse, Toulouse, France (NAA); Hôpital de l'Hôtel-Dieu, Service de Dermatologie, Lyon, France (LT); AP-HP, Groupe Pitié-Salpêtrière, Département de Génétique, Cytogénétique et Embryologie, Paris, France (AB).

\*Authors contributed equally to this work.

**Correspondence to:** Pr. Nadem Soufir, Laboratoire de Génétique, Hôpital Bichat Claude Bernard, AP-HP, 46, rue Henri Huchard, 75018, Paris, France (e-mail: [nadem.soufir@bch.aphp.fr](mailto:nadem.soufir@bch.aphp.fr)).

## Abstract

**Background:** Melanoma incidence is higher in patients affected by Parkinson's disease (PD) and vice versa, but the genetic link shared by both diseases is unknown. As *PARK2* is both a tumor suppressor gene and frequently mutated in young onset PD, we evaluated the role of *PARK2* in melanoma predisposition and progression.

**Methods:** An in-depth *PARK2* gene dosage analysis and sequencing was performed on 512 French case patients and 562 healthy control patients, as well as sporadic tumors and melanoma cell lines. The frequency of genetic alterations was compared between case patients and control patients using two-sided Fisher's exact tests and odds ratio (OR) calculations. We used western blotting to determine *PARKIN* expression in melanocytes and melanoma cell lines and transfection followed by clonogenic assays to evaluate the effect of *PARKIN* expression on cellular proliferation. All statistical tests were two-sided.

**Results:** Germline *PARK2* mutations (including copy number variations, splicing, and putative deleterious missense mutations) were present in 25 case patients but only four control patients (OR = 3.95, 95% confidence interval = 1.34 to 15.75). Copy number variations (CNVs) and loss of heterozygosity were present in 60% and 74%, respectively, of primary tumors. *PARKIN* protein was expressed in melanocytes but not in most melanoma cell lines, and its expression decreased following melanocyte transformation by oncogenic *NRAS*. Re-expression of *PARKIN* in melanoma cell lines resulted in a drastic reduction of cell proliferation and inhibition of *PARKIN* in melanocytes stimulated their proliferation.

Received: February 11, 2015; Revised: May 28, 2015; Accepted: October 15, 2015

© The Author 2015. Published by Oxford University Press. All rights reserved. For Permissions, please e-mail: [journals.permissions@oup.com](mailto:journals.permissions@oup.com).

**Conclusion:** Our results show an important role for PARK2 as a tumor suppressor both in melanoma predisposition and progression, which could explain the epidemiological association of these diseases.

Most cancer rates are lower in patients affected by Parkinson's disease (PD) than in the general population, except for melanoma, a malignant tumor of the melanin-producing cells, which occurs more frequently among patients with PD compared with control patients (1–4). Moreover, melanoma patients are more likely to develop PD than the general population (5), confirming that PD and melanoma are associated. Different hypotheses have been raised to explain this link, including the use of levodopa (a melanin precursor used for the treatment of PD), shared environmental/lifestyle factors such as smoking and socioeconomic status, and common genetic components (6–8). So far, the exact mechanisms underlying the observed melanoma-PD association are not clear. In this work, we investigated whether PARK2, the most frequently mutated gene in PD predisposition could also be implicated in melanoma predisposition and progression. PARKIN, the protein encoded by PARK2, is a RING E3 ubiquitin ligase that catalyzes the attachment of ubiquitin to itself and to multiple putative substrates (9). PARKIN has a wide neuroprotective activity preventing cell death in response to various stresses. Under physiological conditions, PARKIN is involved in maintaining mitochondrial integrity and function and can induce subsequent autophagy of dysfunctional mitochondria (10,11).

A wide spectrum of loss-of-function mutations in PARK2 has been described in PD. They include point mutations such as missense, nonsense, frameshift, and splice site mutations, as well as copy number variations (CNVs) in single or multiple exons (12) that account for 50% of PARK2 mutations in early-onset recessive PD. PARK2 is also a potential tumor suppressor gene, which is inactivated in many cancers including renal cell carcinoma, glioblastoma, colon, lung, and pancreatic cancers (13–17). These alterations occur in the same domains and sometimes at the same residue as the germline mutations that cause PD. To evaluate whether mutations of PARK2 could explain the link between PD and melanoma, we searched for PARK2 alterations in the germline of melanoma patients, as well as in melanoma cell lines and primary tumors.

## Methods

### Patients

For assessment of PARK2 alterations in melanoma predisposition, 512 French melanoma patients were recruited from the dermatology and genetics departments of Bichat and Saint-Louis hospitals (Assistance Publique des Hôpitaux de Paris, France). Among the 512 case patients, 266 (52%) were probands of familial melanoma and 138 (27%) were patients affected by multiple primary melanoma. Other case patients included 88 (17%) patients with single primary melanoma and 20 patients who were affected by both melanoma and Parkinson's disease (4%).

Five hundred sixty-two control patients were enrolled in the study. This group included ethnically matched control patients, mostly healthy spouses of PD patients without family history of PD (2/3) recruited at the Pitié Salpêtrière Hospital (Paris, France), and healthy blood donors (1/3) recruited from the Etablissement Français du Sang (EFS) of Bichat and Saint-Louis hospitals (Paris, France). All the control patients were studied for the presence of PARK2 CNVs, and a subset of 312 patients was for also investigated for PARK2 mutations by Sanger Sequencing. Their mean age at examination was 55 years (SD = 9.6 years, range = 27 to

84 years). All case patients and control patients gave signed, informed consent. The local ethics committee approved the study.

### Melanoma Tumors and Cell Lines

Melanoma tumor samples (n = 31) from the Saint Louis Hospital (Paris, France) and Henri Mondor Hospital (Créteil, France) were obtained following participant consent and with institutional review board approval. Of these, 24 were metastasis and seven were primary tumors.

Twenty-four melanoma cell lines were also investigated for the presence of PARK2 alterations: WM115, WM266.4, WM1361, SKMel5, SKMel28, Sbc12, C8161, 501Mel, G361, WM1346, UACC257, UACC903, Colo38, FO1, MNT1, MelJuso, 24 /95, WM983B, SLM8, HT144, Mel1, A375, M74, HM11. A PARK2 gene dosage analysis was performed in both tumors and cell lines, and PARK2 was sequenced in cell lines. An additional group of 19 tumors was used to investigate LOH in PARK2.

### Cell Culture and Transfection

Normal neonatal human epidermal melanocytes (NHEM; Cascade Biologics, Nottinghamshire, UK) were cultured in medium 154, supplemented with human melanocyte growth supplement (Cascade Biologics). Melan-a cells were cultured in RPMI 1640 (Gibco, Life Technologies) containing 10% fetal calf serum (FCS; Thermo Fisher Scientific, Brebieres, France), 1% antibiotics penicillin/streptomycin (Invitrogen, Life Technologies), 1% L-glutamine (Invitrogen, Life Technologies), 200 nM TPA (Sigma), and 300 pM cholera toxin (Sigma). Human melanoma cell lines were cultured in DMEM or RPMI 1640 medium (Gibco, Life Technologies) supplemented with 10% FBS, 1% antibiotics penicillin/streptomycin, and 1% L-glutamine. All melanoma cell lines were genotyped to verify their authenticity. Cell lines were transfected with JetPEI (Qiagen, MP Biomedicals, Illkirch, France) or TransIT-LT1 Transfection Reagent (Mirusbio, Souffelweyersheim, France) according to the manufacturer's instructions. Forty-eight hours following transfection, part of the cells were lysed to evaluate protein expression and part of the cells were selected using blasticidin or G418 for colony formation assays. These cells were cultured for two weeks and stained with crystal violet. Colonies were quantified using ImageQuant (GE healthcare). The experiments were done in triplicate and presented as percentage of control (empty vector). The transformation of Melan-a cells with oncogenic <sup>G12V</sup>NRAS was previously described (18).

### Protein Expression and Antibodies

Cells were lysed in RIPA or laemli buffer, and the proteins were subjected to an SDS-PAGE, detected using the following antibodies: mouse monoclonal PARKIN (#4211), cyclin D1 (#2926), cyclin E (#4129), rabbit polyclonal Rb phosphorylated on Ser795 (#9301), and Ser807 (#9308); <sup>G12V</sup>NRAS (#14412) were from Cell Signaling Technology, mouse monoclonal NRAS (F155) was from Santa Cruz Technology, and mouse monoclonal Actin (ACTN05) was from Abcam. All antibodies were diluted to 1/1000 except for NRAS, diluted to 1/200, and were visualized using the SuperSignal West Pico Chemiluminescent Substrate (Thermo Scientific).

## Statistical Analyses

Association analyses compared the number of case patients and control patients carrying *PARK2* mutations. The various types of mutations were compared individually (CNVs, missense, splicing). In addition, inactivating mutations (splicing + frameshift + CNVs) and all putative loss-of-function mutations (splicing + frameshift + CNVs + deleterious missenses) were pooled and compared. Odds ratios (ORs), 95% confidence intervals (CIs), and associated *P* values were assessed by Fisher's exact test (*fisher.test* function of R v2.14.0, <http://www.R-project.org>, the R Foundation for Statistical Computing, Vienna, Austria). The numbers of colonies was compared with the paired Student's *t* test. All statistical tests were two-sided.

## Supplementary Methods

Sanger sequencing, gene-dosage analysis, in-silico prediction tools, microsatellite analysis, and vectors are described in the [Supplementary Materials](#) (available online).

## Results

A *PARK2* gene dosage analysis was performed on 512 French melanoma patients and 562 healthy control patients by Multiplex ligation-dependent probe amplification (MLPA). Ten different exonic CNVs were detected in melanoma patients by MLPA and confirmed by quantitative polymerase chain reaction and CGH array ([Supplementary Table 1](#) and [Figures 1 and 2](#), available online). These CNVs included five deletions and five duplications and involved numerous contiguous exons in 10 patients ([Supplementary Table 1](#) and [Figures 1 and 2](#), available online). They were present in four familial melanoma patients, two patients with multiple primary melanoma, one patient affected by both PD and melanoma, and three patients with a single melanoma ([Supplementary Table 1](#), available online). Interestingly, CNVs were homozygous in two patients, one of which had both PD and melanoma, while the other had familial melanoma. All exons, except exons 7 and 9, were affected by CNVs in melanoma patients. In the 562 healthy control patients, only two CNVs were detected, involving exon 2 ([Supplementary Table 1](#) and [Figure 1](#), available online). *PARK2* exonic duplications may lead to alternative splicing or exon

skipping, and deletion of some exons can cause in-frame or out-of-frame fusion products. The frequency of *PARK2* CNVs was compared between melanoma patients and the ethnic- and sex-matched healthy control patients: *PARK2* CNVs were found to be statistically significantly associated with melanoma (OR = 6.18, 95% CI = 0.87 to 269.4, *P* = .06). This association was confirmed using 2060 healthy control patients (control group 2) from previous studies who had been investigated for *PARK2* constitutional alterations (OR = 5.11, 95% CI = 1.18 to 14.97, *P* < .001) ([Table 1](#)).

The size of CNVs tended to be larger in melanoma patients than in control patients ([Supplementary Table 1](#) and [Figure 1](#), available online). By comparing our data with that of a large series of control patients (9), we observed that the mean number of exons affected by CNVs was statistically significantly higher in melanoma patients (Student's *t* test, *P* = .0019). Furthermore, *PARK2* CNVs identified in melanoma patients involved *PARK2* critical functional domains, whereas CNVs identified in healthy control patients were restricted to exon 2 in our study ([Figure 1](#)) and to exons 2–4 in a previous study (9).

We sequenced the entire coding region of *PARK2* in 512 melanoma patients and in 312 control patients (a subset of the 562 control patients investigated for CNVs) by the Sanger method and characterized 20 rare *PARK2* variants ([Supplementary Table 2](#) and [Supplementary Figure 1](#), available online). We identified two novel intronic variants (c.8-14A>G and c.8-1delG) present in three patients (two patients affected with multiple melanoma and one patient with single sporadic tumor), which were predicted to affect mRNA splicing either by creating a new acceptor site or by abolishing an existing one. To confirm this hypothesis, blood RNA from two patients carrying these variants was extracted, amplified by real-time polymerase chain reaction (RT-PCR), and sequenced. The c.8-14A >G variant created a new splice site 14bp upstream of the original splice site ([Supplementary Figure 2](#), available online), leading to the addition of 14bp at the 5'UTR mRNA. The c.8-1delG variant abolished the original acceptor splice site, leading to a new acceptor splice site 10bp downstream in exon 2 and to a 10bp shorter mRNA ([Supplementary Figure 2](#), available online). Splicing variants were also statistically significantly associated with melanoma when compared with control patients from previous publications (*P* = .0079), and data from the exome variant server (<http://evs.gs.washington.edu/EVS/>) confirmed that splicing *PARK2*

**Table 1.** Association of *PARK2* rare variants with melanoma risk

Variants	Patients (n = 512)	Control group 1*			Control group 2†		
		n = 312	OR (95% CI)	<i>P</i> ‡	n = 2060	OR (95% CI)	<i>P</i> ‡
Splicing	3	0	-	-	0	-	-
Frameshift	1	1	0.61 (0.01 to 47.93)	1.00	3	1.34 (0.03 to 16.75)	.59
Copy number variation	10 (2 HOM) §	1	6.18 (0.87 to 269.4)	.06	8	5.11 (1.8 to 14.97)	<.001
Inactivating variants‖	14 (2 HOM) §	2	4.35 (0.99 to 39.63)	.04	11	5.23 (2.19 to 12.82)	<.001
Missense deleterious	12	2	3.72 (0.82 to 34.40)	.09	32	1.52 (0.71 to 3.06)	.25
Variants with probable functional effect	25 (2 HOM + 1 CH) §	4	3.95 (1.34 to 15.75)	.0058	43	2.41 (1.39 to 4.08)	<.001
Intronic	23	5	2.92 (1.05 to 8.79)	.0287	11	8.75 (4.07 to 20.02)	<.001
Missense nondeleterious	2	1	1.22 (0.06 to 72.15)	1.00	10	0.80 (0.09 to 3.79)	1.00

\* Control group 1 comprised 312 healthy control patients recruited in this study. CH = compound heterozygous; CI = confidence interval; HOM = homozygotes; OR = odds ratio.

† Control group 2 comprised 2060 healthy control patients derived from PDmutDB, which were studied for both point mutation and copy number variation.

‡ *P* values were calculated by Fisher's exact test on the number of individuals with at least one variant.

§ Parentheses indicate the number of individuals who are homozygous or have two variants.

‖ Inactivating variants include splicing and frameshift variants and copy number variations.

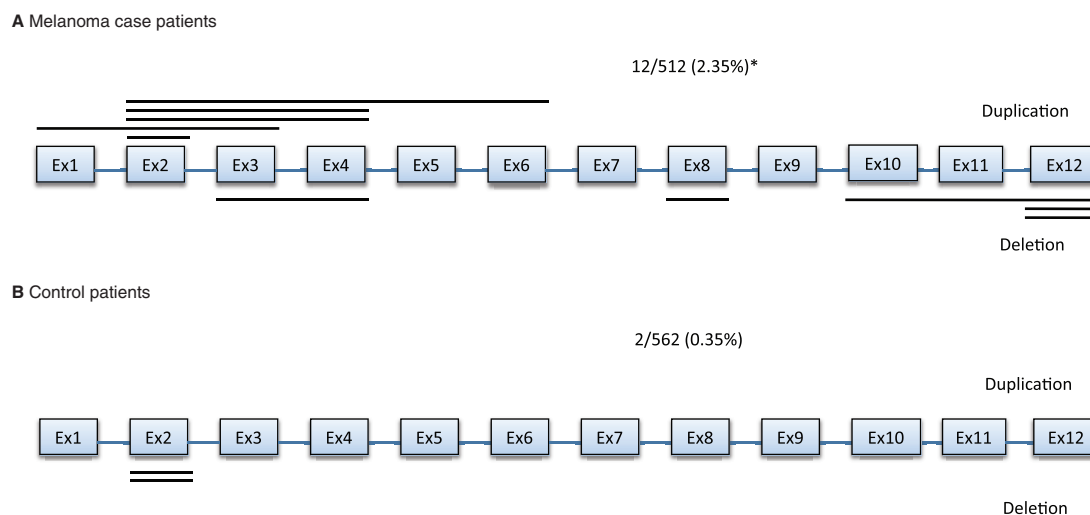

**Figure 1.** Localization and size of exonic *PARK2* copy number variations (CNVs) identified in melanoma case patients (A) and control patients (B). Blue boxes indicate *PARK2* exons, and black lines indicate the extent of duplication (on top of the exons) and deletions (below the exons). The frequency of CNVs is indicated on top of the exons. \*Two CNVs were homozygous in two patients.

variants were extremely rare in the general population (one variant in 13010 alleles).

We also found two frameshift mutations located in the ubiquitin-like domain (Supplementary Table 2 and Supplementary Figure 1, available online), which were previously reported as pathogenic for PD: one in a familial melanoma patient and one in a control. We also detected six rare missense variants (Pro153Arg, Asn273Ser, Arg275Trp, Arg402Cys, and Pro437Leu), which have been previously associated with PD (19), and five of them were predicted to be deleterious by at least one in silico prediction tool. These putative deleterious variants were present in 13 patients (2.5%; 8 familial melanoma probands, 3 multiple melanoma patients, 2 single melanoma patients) and in three control patients (0.9%). Three of them (Asn273Ser, Arg275Trp and Pro437Leu) were located in the zinc finger rings 1 and 2, which are crucial for protein-protein interaction during PARKIN-mediated ubiquitination (Supplementary Figure 1, available online). One patient (P988) carried a *PARK2*-deleterious mutation (c.1204C>T p.R402C) and a duplication involving exons 2–4.

Interestingly, the sequencing of regions flanking each exon allowed us to identify rare intronic variants in 4.49% of patients and 1.6% of control patients, which tended to associate with melanoma risk (Table 1; Supplementary Table 2, available online). The possibility that these variants affect mRNA splicing, because they are located very close to the exon boundaries, remains to be elucidated.

Germline *PARK2* mutations were present in 25 case patients but only four control patients. Collectively, the putative *PARK2*-inactivating variants (including splicing, frameshift, CNVs, and predicted deleterious missense mutations) were strongly associated with melanoma risk when compared with the two control groups (OR = 3.95, 95% CI = 1.34 to 15.75, for control group 1; OR = 2.41, 95% CI = 1.39 to 4.08, for control group 2) (Table 1). The repartition of *PARK2*-inactivating variants was the same for each melanoma subgroup (familial 4.5%, multiple 5%, and sporadic 5.6%).

Most *PARK2* germline alterations were heterozygous in melanoma patients, suggesting that one mutated *PARK2* allele is sufficient to modulate melanoma risk. However, three patients were either homozygous for *PARK2* CNVs (O734, O1281) or composite heterozygous for a CNV and a missense mutation

(P988). Interestingly, using three microsatellites localized in *PARK2*, loss of heterozygosity (LOH) at the *PARK2* locus could be demonstrated in tumors from three patients carrying a constitutional *PARK2* mutation or CNV (Supplementary Figure 3A, available online). These results suggest that in some cases melanoma development occurs through the inactivation of the second allele and that *PARK2* acts as a tumor suppressor gene in melanoma.

To evaluate the general role of *PARK2* on melanoma oncogenesis, a gene dosage analysis was performed in 31 sporadic tumors and 24 melanoma cell lines. Sixty-two percent (19/31) of tumors had an alteration of the *PARK2* locus (Figure 3, A and B). All 12 exons in the *PARK2* gene were deleted in four tumors (13%), while another four tumors (13%) carried deletions in some exons. Duplication of all 12 exons was observed in six tumors (19%), while five tumors (16%) carried partial exonic duplications in the *PARK2* gene. Amongst the 24 melanoma cell lines, 71% (17/24) presented an alteration of the *PARK2* locus. Eight (33%) showed a complete deletion of *PARK2*, while nine (38%) showed a partial deletion in the *PARK2* gene. In addition, three *PARK2* mutations were identified: One melanoma cell line carried a homozygous novel missense mutation c.1216G>A (p.A406T) that involved a conserved residue and was predicted to be possibly damaging (Supplementary Figure 4, available online); another melanoma cell line carried a homozygous substitution in the 3'UTR (g. 161771023 T>C), and, interestingly, a sporadic tumor carried a splice mutation in intron 3 (IVS3+2 A>T). Furthermore, using microsatellite analysis, an LOH in *PARK2* was investigated in 19 additional melanoma tumors and was observed in 14 of 19 (74%, see examples in Supplementary Figure 3, available online), emphasizing the role of *PARK2* as a tumor suppressor in melanoma development.

A reanalysis of CGH data from 60 human cell lines from metastasized melanoma and from 44 corresponding peripheral blood mononuclear cells confirmed an LOH at the *PARK2* locus in melanoma tumors (20). These data are also coherent with that of the cosmic database (<http://cancer.sanger.ac.uk/cosmic/>), where an LOH in *PARK2* is seen in 43% of melanoma cell lines. Three out of seven primary tumors (43%) and 16 out of 24 metastatic tumors (66%) harbored a *PARK2* mutation, suggesting that *PARK2* inactivation may occur preferentially during



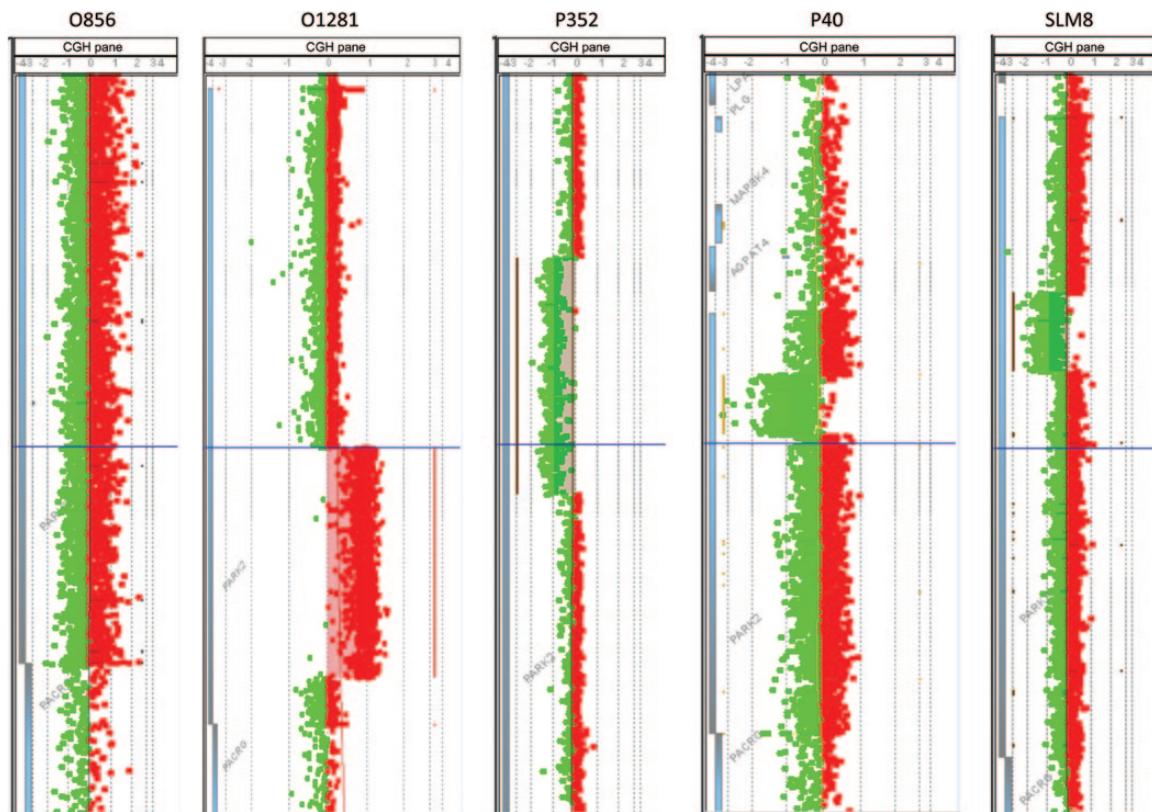

Figure 2. Examples of duplications of *PARK2* exons (O1281) and deletions of *PARK2* exons (P352, P40) in lymphocytic DNAs from patients and deletions of *PARK2* exons (SLM8) in a melanoma tumor detected by CGH arrays. Lymphocytic DNA from O856 is used as a wild-type control.

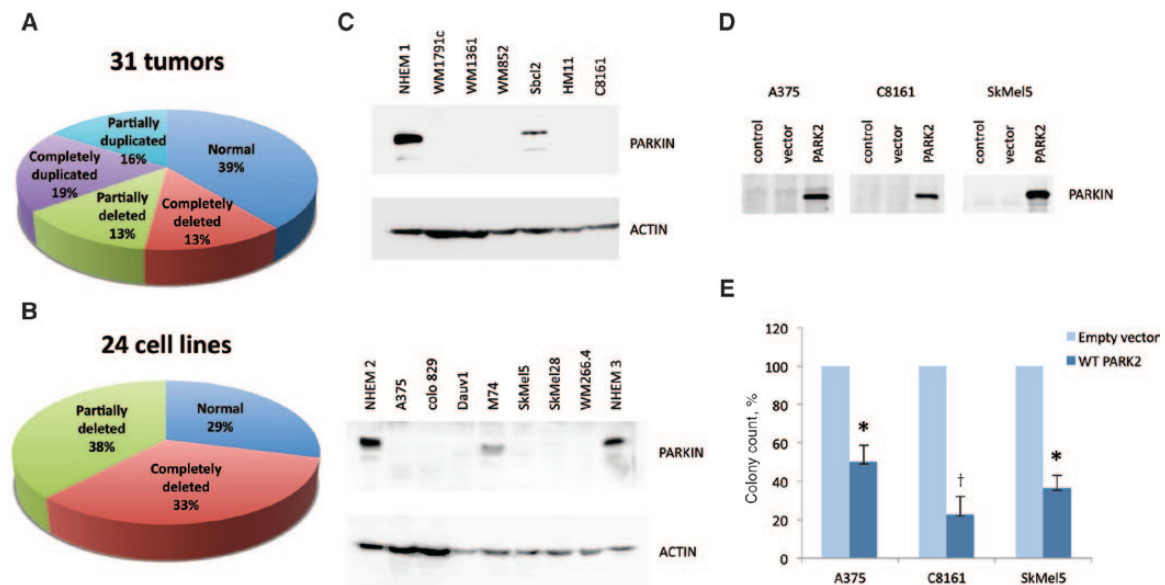

Figure 3. *PARK2* alterations in melanoma biopsies and melanoma cell lines. Number and percentage of tumors (A) and melanoma cell lines (B) carrying *PARK2* copy number variations. C) PARKIN expression in normal human melanocyte (NHEM) and in melanoma cell lines mutated on *NRAS* (upper blot) or *BRAF* (lower blot). D) PARKIN expression in the indicated cell lines after transfection with control vector (left lane), empty vector (middle lane), and vector containing wild-type (WT) *PARK2* cDNA (right lane). E) Colony formation assay of indicated melanoma cell lines transfected with empty vector and vector containing WT *PARK2* cDNA. Graph represents the mean  $\pm$  SD of triplicates. Similar results were obtained in two independent experiments. Paired Student's *t* test;  $P = .02^*$  and  $P = .002^\dagger$ .

melanoma progression or metastasis, but this needs to be confirmed by testing on a larger sample size.

As the *PARK2* gene is frequently deleted or duplicated in melanoma tumors and cell lines, we assessed the expression of the PARKIN protein in primary melanocytes compared with

melanoma cell lines carrying either *BRAF* or *NRAS* mutations, which are the most frequently mutated oncogenes in melanoma (21). PARKIN protein was expressed in three different primary melanocytes (NHEM); however, its expression was lost in most tested melanoma cell lines that carried either a *BRAF* or a *RAS*

mutation (Figure 3, C). PARKIN was only expressed in two of 14 (14%) melanoma cell lines.

To investigate whether PARKIN could act as a tumor suppressor in melanoma cell lines, three melanoma cell lines carrying either a mutation on BRAF or a mutation on RAS and that do not express endogenous PARKIN were stably transfected with a vector expressing wild-type PARK2 cDNA. The expression of PARKIN in the transfected cells was evaluated by western blotting, and the effect of PARKIN expression on cell proliferation was analyzed by colony formation assay. Interestingly, the number of colonies was strongly reduced in cells expressing PARKIN compared with cells transfected with the empty vector (Figure 3, D and E), suggesting that PARKIN can act as a tumor suppressor in melanoma and that its loss may cooperate with mutated BRAF or NRAS to transform melanocytes.

To further study the effect of melanocyte transformation by an oncogene on PARKIN expression, we used the Melan-a cell line, a nontransformed mouse melanocyte line that retains many of the characteristics of normal melanocytes. Melan-a cells were transformed by oncogenic  $G^{12V}$  NRAS, as previously described (18), and the expression of PARKIN was compared between the parental cell line and five independent transformed clones (Figure 4, A and B). We showed that whereas PARKIN was expressed in mouse melanocytes and in human melanocytes, its expression was strongly reduced (by 61% to 97%) in all transformed clones expressing  $G^{12V}$  NRAS. These results show that PARKIN expression is lost or reduced during melanocyte transformation.

To determine the biological effect of inhibiting PARKIN expression in melanocytes, we used RNA interference to reduce PARKIN expression in melanocytes. Two different microRNA (PARK2-A and PARK2-B) specifically targeting PARKIN were stably expressed in melanocytes and their effect on melanocyte proliferation analyzed in a clonogenic assay. PARK2-A and PARK2-B microRNA, but

not the control patients, reduced the expression of PARKIN in melanocytes by 70% (Supplementary Figure 5, available online). We obtained statistically significantly more clones in a clonogenic assay with melanocytes expressing PARK2 microRNA than with control, showing that reduction in PARKIN expression stimulates melanocyte proliferation (Figure 4, C and D). As PARK2 inactivation was previously shown to result in cyclin D1 and E accumulation in cancer cells, we analyzed the level of these proteins in our cells but did not detect any increase in cyclin D1 or E expression associated with PARKIN reduction. Moreover, we did not detect any effect of PARKIN inhibition on Rb phosphorylation, a substrate of cyclin-CDK complexes (Supplementary Figure 5, available online).

## Discussion

An association between Parkinson's disease and malignant melanoma has long been suspected, and an increase in epidemiological evidence reported in the last decade has reaffirmed this connection (2). To understand the molecular mechanism of this connection, we analyzed the role of PARK2 in melanoma predisposition and development. The PARK2 gene is mutated in 21% of familial PD patients in the Caucasian population, and mutations in this gene represent 48% of all pathogenic mutations identified in the five causal genes connected to PD. In addition, PARK2 alterations have already been associated with cancer (2,17), making this gene an ideal candidate for assessing the relationship between melanoma and PD.

We identified 12 CNVs in our patient population, which were statistically associated with melanoma when compared with two different control groups (Table 1). In addition, the size of PARK2 CNVs identified in our melanoma patients was statistically significantly higher than in previously published control patients ( $P = 1.90E-03$ ) (9). PARK2 CNVs identified in our melanoma patients covered almost the entire gene and involved PARK2

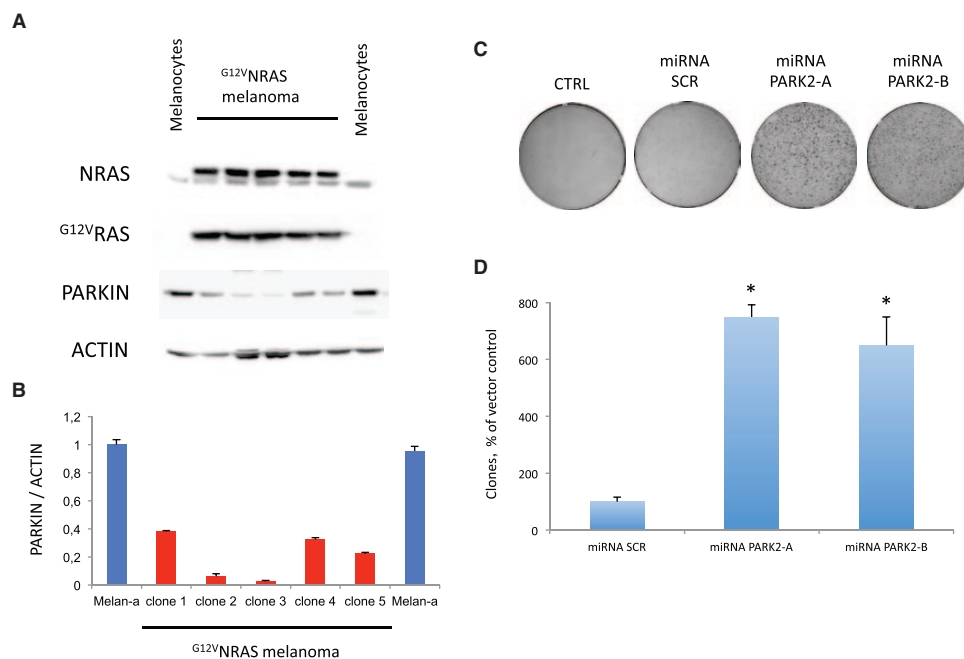

**Figure 4.** PARKIN inhibits melanocyte proliferation and transformation by oncogenic NRAS. **A)** Immunoblots of total NRAS,  $G^{12V}$ NRAS, PARKIN, and ACTIN in normal melanocytes and five independent clones (clones 1 to 5) of melanocytes transformed by oncogenic  $G^{12V}$ NRAS. Western blots were quantified to evaluate the ratio PARKIN/ACTIN and graph in **(B)** represents the mean  $\pm$  SD of two independent experiments. **C)** Colonies of melanocytes transfected with a control vector, a vector expressing a scramble microRNA (miSCR), or a microRNA-targeting PARK2 (miPARK2-A and miPARK2-B) and selected with blasticidin. **D)** Graph, mean  $\pm$  SD of triplicates. Similar results were obtained in three independent experiments. Paired Student's *t* test;  $P = .02^*$ .

critical functional domains, whereas CNVs identified in the control patients were restricted to exon 2 to exon 4, suggesting that the PARK2 gene alterations are more deleterious in melanoma patients than in the control population. Therefore, PARK2 CNVs appear to be an important risk factor for melanoma predisposition, increasing the risk of melanoma by five to six times. In PD, PARK2 mutations are transmitted in an autosomal recessive manner. Interestingly, most PARK2 germline mutations identified in melanoma patients were heterozygous, suggesting that one mutated PARK2 allele is sufficient to increase the risk of melanoma.

In this study, we also identified two frameshift mutations located in the ubiquitin-like domain of PARKIN and six rare missense variants (Supplementary Table 2 and Supplementary Figure 1, available online), which were previously reported as pathogenic for PD (19). Five of the missense variants were predicted to be deleterious by at least one in silico prediction tool. Further functional studies will be necessary to assess their role in melanoma.

The PARK2 gene comprising 12 exons spans approximately 1.38Mb with an extremely high portion of introns. The sequencing of regions flanking each exon allowed us to identify a spectrum of intronic variants, which tended to be associated with melanoma risk (Table 1; Supplementary Table 2, available online). Although two variants were shown to affect mRNA splicing by RT-PCR, most of these intronic variants were predicted to have no effect on mRNA splicing. However, they could influence the binding of transcription factors or regulators and therefore change the expression profile of PARK2 mRNA. Furthermore, we identified PARK2 CNVs in 70% of melanoma cell lines and 60% of primary tumors and showed that PARKIN was not expressed in most melanoma cell lines. Interestingly, LOH at the PARK2 locus could be demonstrated in tumors from three patients carrying a constitutional PARK2 mutation or CNV (Supplementary Figure 3, available online) and in 14 out of a subset of 19 melanoma tumors (74%). Together, these findings show that PARK2 is frequently rearranged in melanoma and that PARK2 inactivation is concurrent with melanoma progression. PARK2 inactivation occurs as frequently in BRAF-mutated melanoma as in NRAS-mutated melanoma but, interestingly, was less frequent in acral melanoma or mucosal melanoma (2/6 tumors) than in other melanomas (17/25).

It is notable that re-expression of PARKIN in three different melanoma cell lines (carrying either a mutation on BRAF or a mutation on RAS) strongly reduced proliferation. Moreover, melanocyte transformation by oncogenic NRAS induced a reduction in PARKIN expression. These data strongly suggest that PARKIN can act as a tumor suppressor in melanoma, where it prevents transformation by an oncogene. Its loss may therefore cooperate with mutated BRAF or NRAS to transform melanocytes. Tumor-suppressor genes generally encode proteins that in one way or another inhibit cell proliferation, and their loss promotes cancer cell proliferation. We showed that reduction of PARKIN expression in melanocytes statistically significantly increased colony formation in agreement with recent data showing that depletion of PARK2 resulted in increased proliferation of colon and glioblastoma cell lines (17). Altogether, these data confirm the tumor-suppressing properties of PARK2 in melanoma development.

This study also had some limitations. Notably, the number of patients and control patients in this study was relatively small, and we did not yet perform replication studies. Therefore, additional studies should be done with more patients and control patients in the French population and in other populations to consolidate our data.

The molecular mechanism behind PARKIN tumor suppressor activity in melanoma is still unclear. There is evidence in several

cancers that PARKIN exerts its tumor-suppressing effect by regulating cyclin D and E degradation through its ubiquitin ligase activity (14,17,22). However, in melanocytes and melanoma cell lines, we did not detect any effect of PARKIN on cyclin E and D1 expression or on Rb phosphorylation, a downstream target of cyclin-CDK complexes (Supplementary Figure 6, available online). These data suggest that PARKIN exerts its tumor suppressor effect in melanocytes through a different pathway from that used in colon cancer or glioblastoma. Considering the essential role of PARKIN in maintaining mitochondrial integrity and function and the changes in mitochondrial dynamics and structure that happen during malignant transformation, one can speculate that PARKIN exerts its tumor suppressor function in melanoma through mitochondria. Given unique antioxidant mechanisms in melanocytic cells (eg, linked to melanin) and the peculiar interplay between ROS and hypoxia (both mitophagy inducers) in melanoma, PARK2 activity in mitochondrial turnover may be involved in a novel mechanism of tumor progression in melanoma. The molecular mechanisms by which PARKIN alteration promotes melanoma development need further investigation.

To our knowledge, this is the first study to have shown that PARK2-inactivating mutations, particularly PARK2 CNVs, increase the risk of melanoma by five to six times and that PARK2 plays a tumor suppressor role in melanoma. Alterations in the PARK2 gene may therefore explain part of the molecular mechanism behind the connection between PD and melanoma.

## Funding

This work was supported by France-Parkinson Association, the French program “Investissements d’avenir” funding (ANR-10-IAIHU-06), the French Society of Dermatology, the Ligue Nationale Contre le Cancer, the Fondation ARC pour la Recherche sur le Cancer, and the Fondation de France. Sponsors had no role in the design of the study; the collection, analysis, or interpretation of the data; the writing of the manuscript; or the decision to submit the manuscript for publication.

## Note

The authors declare no competing financial interests.

## References

- Bertoni JM, Arlette JP, Fernandez HH, et al. Increased melanoma risk in Parkinson disease: a prospective clinicopathological study. *Arch Neurol*. 2010;67(3):347–52.
- Garber K. Parkinson's disease and cancer: the unexplored connection. *J Natl Cancer Inst*. 2010;102(6):371–374.
- Liu R, Gao X, Lu Y, et al. Meta-analysis of the relationship between Parkinson disease and melanoma. *Neurology*. 2011;76(23):2002–2009.
- Rugbjerg K, Friis S, Lassen CF, et al. Malignant melanoma, breast cancer and other cancers in patients with Parkinson's disease. *International journal of cancer. J Int Cancer*. 2012;131(8):1904–1911.
- Baade PD, Fritschi L, Freedman DM. Mortality due to amyotrophic lateral sclerosis and Parkinson's disease among melanoma patients. *Neuroepidemiology*. 2007;28(1):16–20.
- Devine MJ, Plun-Favreau H, Wood NW. Parkinson's disease and cancer: two wars, one front. *Nat Rev Cancer*. 2011;11(11):812–823.
- Inzelberg R, Rabey JM, Melamed E, et al. High prevalence of malignant melanoma in Israeli patients with Parkinson's disease. *J Neural Transm*. 2011;118(8):1199–1207.
- Pan T, Li X, Jankovic J. The association between Parkinson's disease and melanoma. *International journal of cancer. J Int Cancer*. 2011;128(10):2251–2260.
- Kay DM, Stevens CF, Hamza TH, et al. A comprehensive analysis of deletions, duplications, and copy number variations in PARK2. *Neurology*. 2010;75(13):1189–1194.
- Exner N, Treske B, Paquet D, et al. Loss-of-function of human PINK1 results in mitochondrial pathology and can be rescued by parkin. *J Neuroscience*. 2007;27(45):12413–12418.

11. Narendra D, Tanaka A, Suen DF, et al. Parkin is recruited selectively to impaired mitochondria and promotes their autophagy. *J Cell Biol.* 2008;183(5):795–803.
12. Hattori N, Kitada T, Matsumine H, et al. Molecular genetic analysis of a novel Parkin gene in Japanese families with autosomal recessive juvenile parkinsonism: evidence for variable homozygous deletions in the Parkin gene in affected individuals. *Ann Neurol.* 1998;44(6):935–941.
13. Toma MI, Grosser M, Herr A, et al. Loss of heterozygosity and copy number abnormality in clear cell renal cell carcinoma discovered by high-density affymetrix 10K single nucleotide polymorphism mapping array. *Neoplasia.* 2008;10(7):634–642.
14. Veeriah S, Taylor BS, Meng S, et al. Somatic mutations of the Parkinson's disease-associated gene PARK2 in glioblastoma and other human malignancies. *Nat Genet.* 2010;42(1):77–82.
15. Pouligiannis G, McIntyre RE, Dimitriadi M, et al. PARK2 deletions occur frequently in sporadic colorectal cancer and accelerate adenoma development in Apc mutant mice. *Proc Natl Acad Sci U S A.* 2010;107(34):15145–15150.
16. Sun X, Liu M, Hao J, et al. Parkin deficiency contributes to pancreatic tumorigenesis by inducing spindle multipolarity and misorientation. *Cell Cycle.* 2013;12(7):1133–1141.
17. Gong Y, Zack TI, Morris LG, et al. Pan-cancer genetic analysis identifies PARK2 as a master regulator of G1/S cyclins. *Nat Genet.* 2014;46(6):588–594.
18. Marquette A, Andre J, Bagot M, et al. ERK and PDE4 cooperate to induce RAF isoform switching in melanoma. *Nat Struct Mol Biol.* 2011;18(5):584–591.
19. Nuytemans K, Theuns J, Cruts M, et al. Genetic etiology of Parkinson disease associated with mutations in the SNCA, PARK2, PINK1, PARK7, and LRRK2 genes: a mutation update. *Hum Mut.* 2010;31(7):763–780.
20. Gast A, Scherer D, Chen B, et al. Somatic alterations in the melanoma genome: a high-resolution array-based comparative genomic hybridization study. *Genes Chromosomes Cancer.* 2010;49(8):733–745.
21. Flaherty KT, Hodi FS, Fisher DE. From genes to drugs: targeted strategies for melanoma. *Nat Rev Cancer.* 2012;12(5):349–361.
22. Yeo CW, Ng FS, Chai C, et al. Parkin pathway activation mitigates glioma cell proliferation and predicts patient survival. *Cancer Res.* 2012;72(10):2543–2553.